

General information

Unloading:

The panels can be unloaded from a lorry using a forklift truck or a crane. When lifting, special care must be taken to ensure that the panels cannot slip or fall off.

Storage: Never stack directly more than 20 panels at a time.

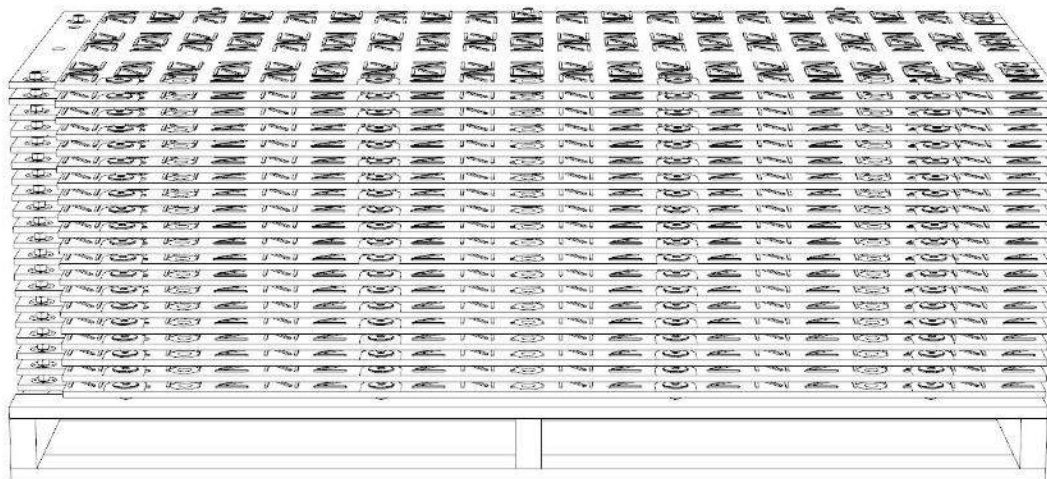

Storage: Never stack more than 20 panels on a stake rack.

Do not move more than 2 stake racks at a time using a forklift truck.

Move only one stake rack at a time using a chain sling.

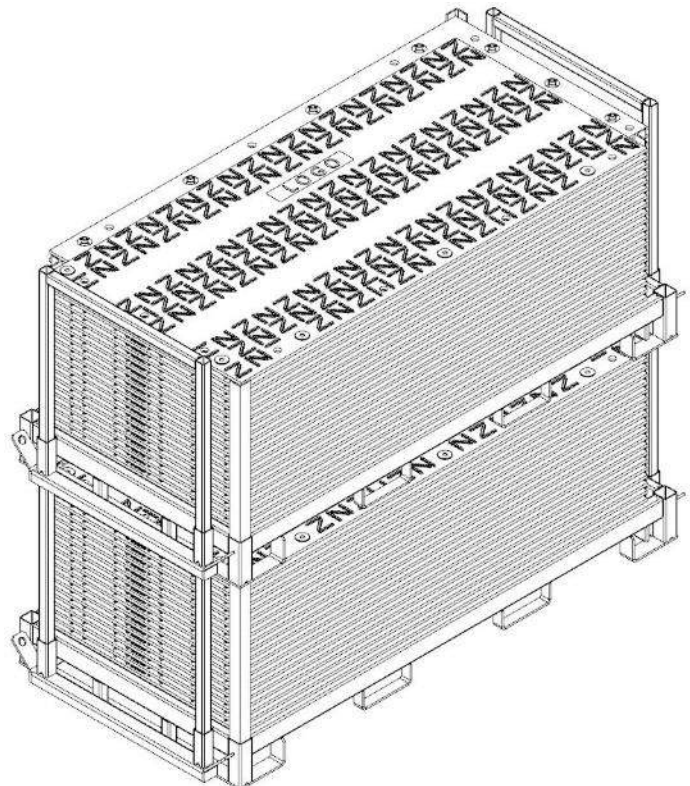

Use of the panels:

Both sides of the panel can be used. The upper side has a high profile surface (suitable for the use of construction vehicles).

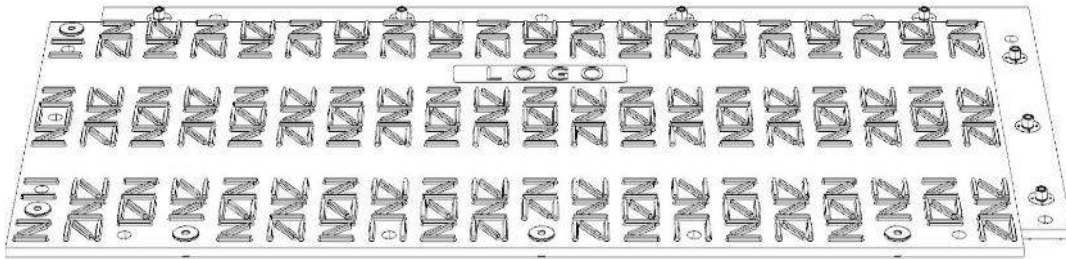

The underside has a lower profile pattern (suitable for predominant use by pedestrians).

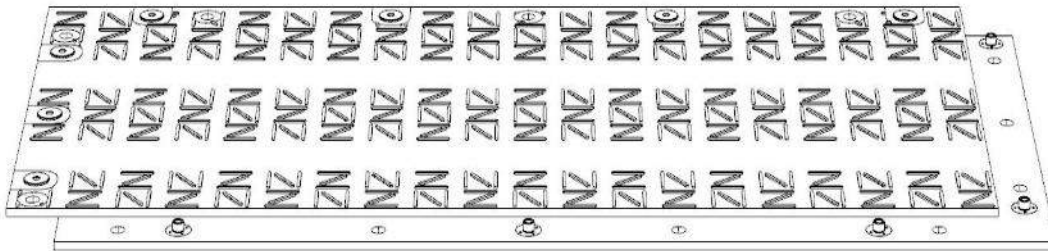

Connecting the panels:

The panels are connected and screwed together using washers and screws (M16x30mm). All adjacent panels must be connected in this way. Always install the panels so that the surfaces of the same type face upwards.

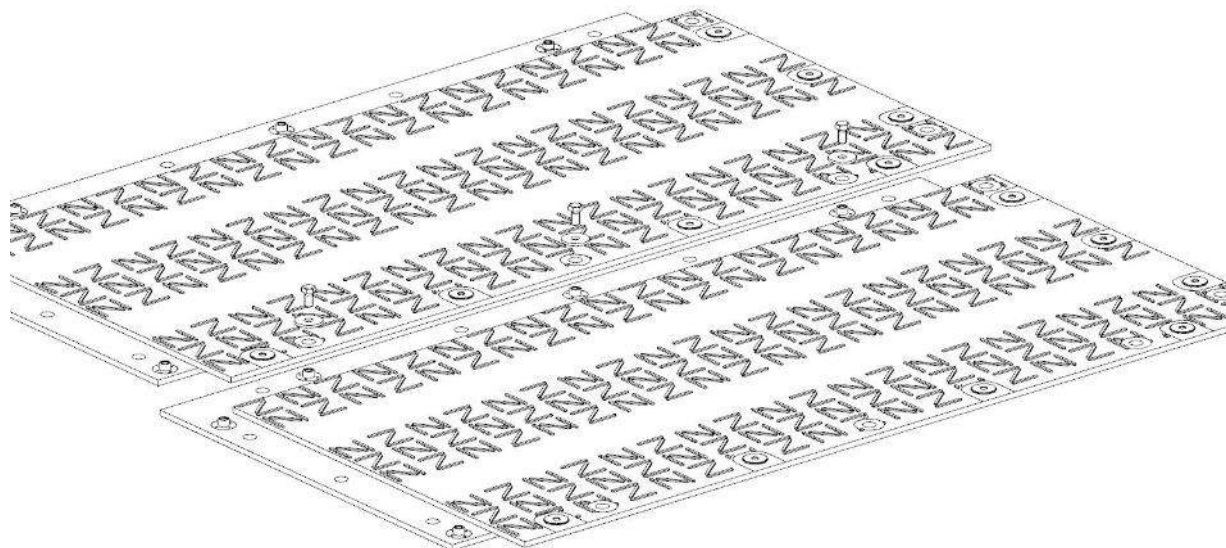

Connecting the panels together (vehicle side):

The panels are connected and screwed together using washers and screws (M16x30mm). All adjacent panels must be connected in this way. Always install the panels so that the surfaces of the same type face upwards.

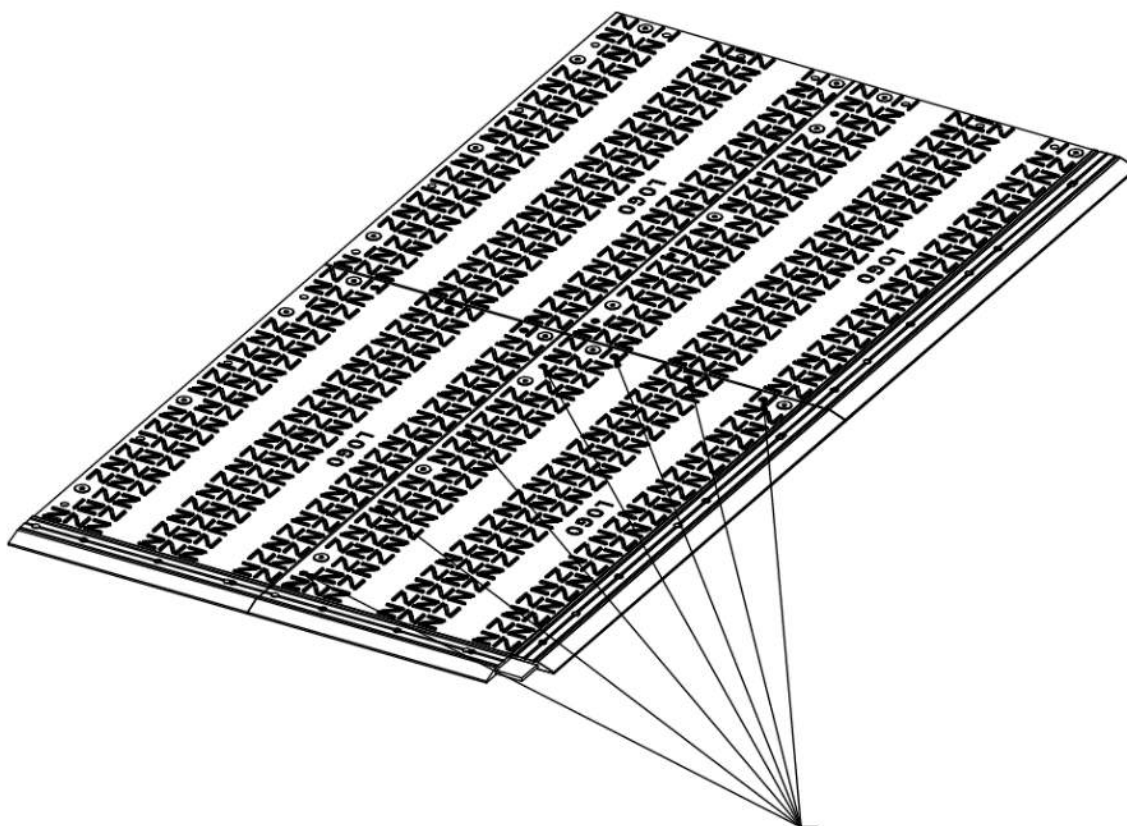

2m side: 4x screws M16x30, 4x washers for screws M16
1m side: 3x screws M16x30, 3x washers for screws M16

Connecting the panels to the ramps (vehicle side):

The panels are connected and screwed together using washers and screws (M16x30mm). All adjacent panels must be connected in this way. Always install the panels so that the surfaces of the same type face upwards.

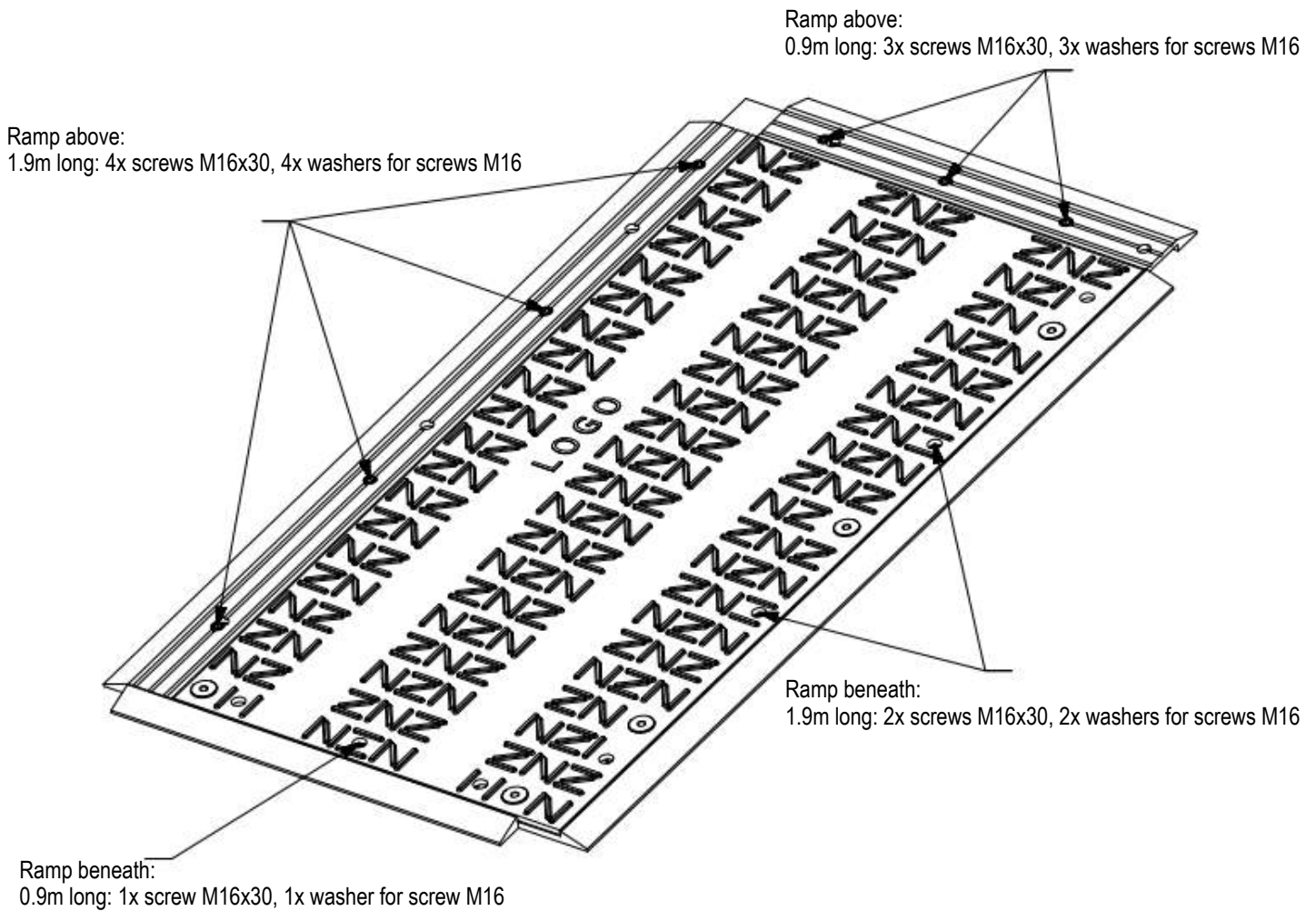

The design of the ramps installed above or beneath the panels, regardless of whether they are used for the vehicle or pedestrian side, is identical. Only the number of connection options differs on the vehicle and pedestrian sides.

VARIO
mat 2

produced by:

OKULEN®

Technische Kunststoffe
Engineering Plastics

Connecting the panels together (pedestrian side):

The panels are connected and screwed together using washers and screws (M16x30mm). All adjacent panels must be connected in this way. Always install the panels so that the surfaces of the same type face upwards.

2m side: 3x screws M16x30, 3x washers for screws M16
1m side: 2x screws M16x30, 2x washers for screws M16

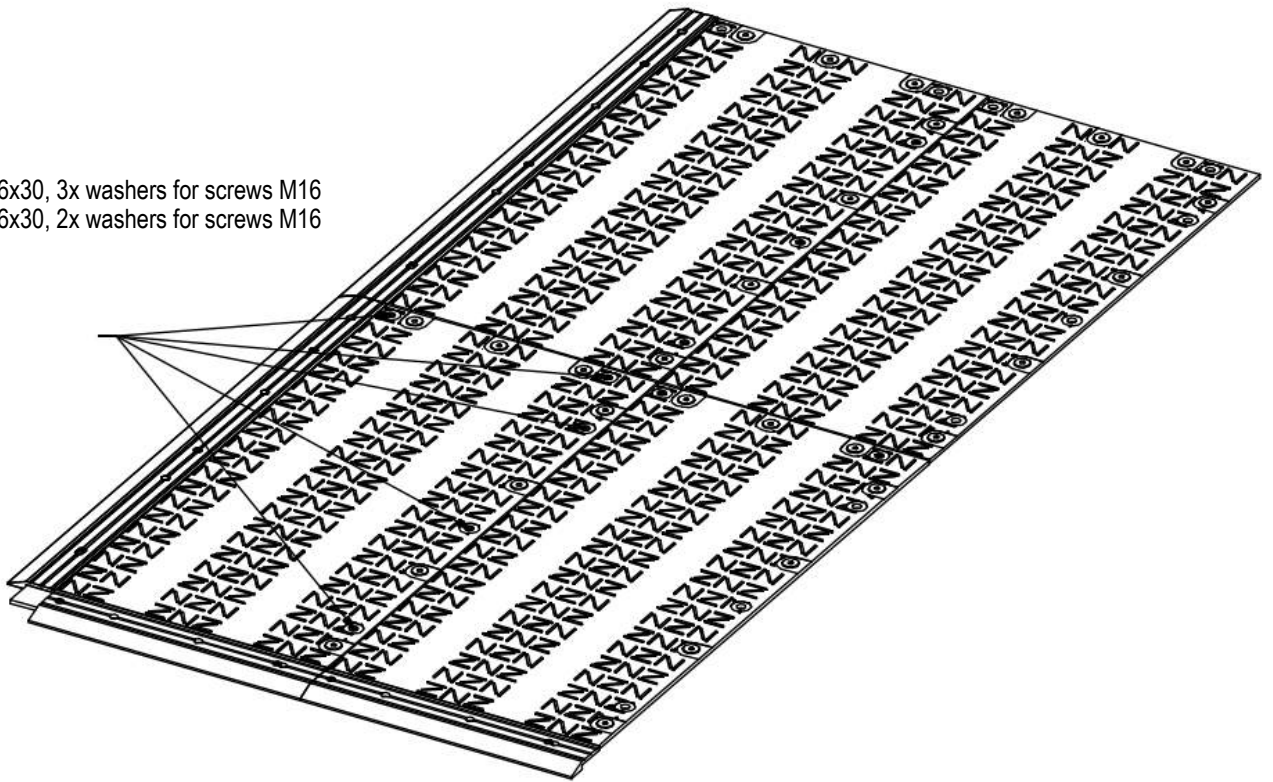

Connecting the panels to the ramps (pedestrian side):

The panels are connected and screwed together using washers and screws (M16x30mm). All adjacent panels must be connected in this way. Always install the panels so that the surfaces of the same type face upwards.

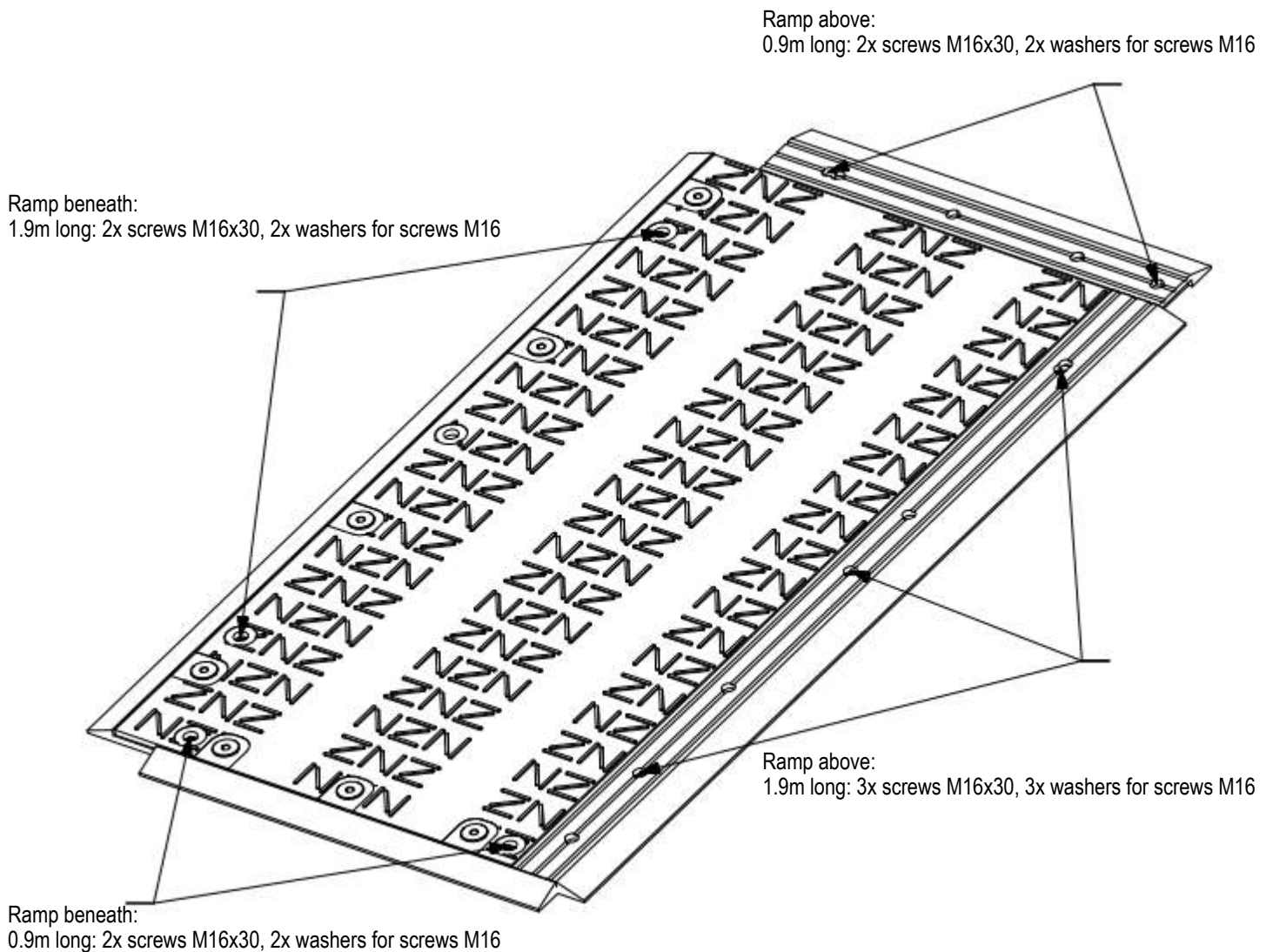

The design of the ramps installed above or beneath the panels, regardless of whether they are used for the vehicle or pedestrian side, is identical. Only the number of connection options differs on the vehicle and pedestrian sides.